

# High Resistance Grounding OEM Kit

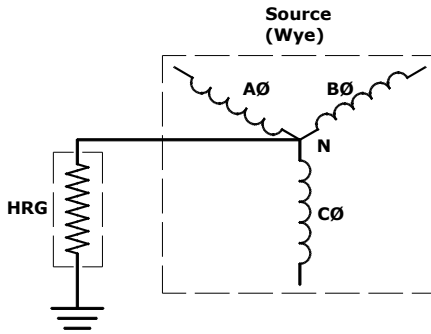

Line to ground faults are the cause of 98% of all plant electrical failures. With increased attention industry-wide to lowering the potentially deadly effects of arcing faults, tackling the problem at its source remains the surest method of increasing your network's reliability. Downtime costs in both productivity and profits, and Post Glover's Pulser Plus Pro keeps plants running 24/7/365.

The benefits of high resistance grounding have long been recognized when compared

to ungrounded or solidly grounded systems. Post Glover's Pulser Plus Pro is the only digital high resistance grounding system with pulsing available today. Available in an OEM kit suitable for mounting in low or medium voltage switchgear cubicles or standard MCC's, its ease of installation, top-level factory support and overall superiority make this the easy choice when the customer requires a pulsing system for complete ground protection.

Productivity Impact		System Type			
		Ungrounded System	Solidly Grounded System	Low Resistance Grounded System	High Resistance Grounded System
Equipment Damage	Overvoltages	Severe	None	Limited	Limited
	Overcurrent - Damage at point of fault	Unknown	Severe	Minimal	None
	Maintenance Costs	High	Reasonable	Reasonable	Low
Downtime	Continuous Operation with Ground Fault	Possible but not recommended	Not possible	Not possible	Ideal
	Relay Co-ordination (Appropriate Equipment Tripped, Ease of fault location)	Difficult	Difficult	Good	Excellent
Personnel	Safety to Personnel	Poor	Good	Good	Excellent

## Features of the Pulser Plus Pro

### Adjustable Pulse Rate

The pulsing signal can be adjusted from 10 pulses per minute to 50 pulses per minute, permitting differentiation between noise and leakage currents.

### Loss of Ground Protection

While rare, a resistor failure can rob you of the benefits of the high resistance grounding system. Using the normally present leakage current, resistor failure can be detected and alarms sounded based on fundamental under-current or under-voltage settings.

### Adjustable time delays

Two separate time delay settings, one each for fundamental and third harmonic settings, prevent nuisance alarms or trips.

Feature	Analog	Digital
Communications	No	Yes
Data logging	No	Yes
Real-time trending	No	Yes
Immune to harmonics	No	Yes
Low cost - space	No	Yes
Low cost - wiring	No	Yes
Easy to install	No	Yes
Accurate	No	Yes

### Generator winding protection

All generators produce a small amount of third harmonics caused by fractional pitch windings. In the event of a fault near the neutral of a wye generator, these values will drop. Separate set-points for third harmonic under-current and under-voltage levels can be used to alarm this condition.

### Harmonic protection

Should normally low third harmonic content increase to potentially damaging levels, over-current and over-voltage levels are provided to allow for alarm purposes.

### Communications

Factory installed options provide the ability to integrate into network monitoring and protection systems via RS232, Modbus or Ethernet protocols.

### Form 'C' contacts

Three sets of dry contacts are included for indication of system changes. One set each is provided for ground fault, high harmonic content and loss of ground indication.

# High Resistance Grounding OEM Kit

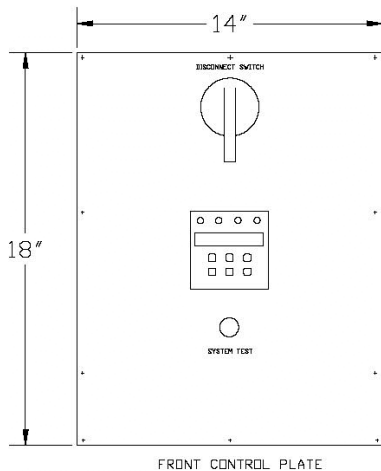

The OEM kit, designed for use at 600 volts and below, consists of three parts: a Front Control Plate, the Internal Control Plate and an enclosed resistor suitable for remote mounting.

All settings can be accessed and adjusted on the display interface module. This module can also be configured to display system status, such as fundamental current and voltage as well as third harmonic levels.

The Front Control Plate is designed to be installed over a cut-out of dimensions 17" high by 13" wide. This is compatible with most OEM switchgear manufacturers. A rectangular shaft couples the disconnect switch handle on the Front Control Plate to the switch

block on the Internal Control Plate when the cubicle door is closed. The distance between the plates is set at installation, and the shaft can be cut to length. The distance between the two plates is typically around 12".

The control power transformer, shown here mounted on the Internal Control Plate, is an available option.

Cabling between the display interface module and the controller is factory supplied. A serial cable is sized to allow for a range of installation possibilities. Custom lengths are available should they be required.

All customer connections, such as the form 'C' contacts, are made on the supplied terminal strip. The controller is pre-wired to the strip, simplifying installation and limiting potential mistakes.

The grounding resistor itself is shipped loose and suitable for mounting on top of the switchgear cabinet.

Approximate resistor dimensions are 29" wide by 18" long by 29" high. The standard enclosure is NEMA 3R with a powder-coated ANSI-61 gray finish, made of mill galvanized steel. Stainless steel enclosures are also available upon request, as are open mounted units for installation inside existing cabinets.

*Save time and money using Post Glover's pre-engineered, easy to install OEM kit. As the industry's leading experts in high resistance grounding, we are constantly pushing the technology and product forward. Trust Post Glover to deliver faultlessly.*

